



Cellular Mount Installation Considerations Glass Mount, Tri-Band VHF/UHF/CEL

GLMT-TB-V/U/C

VERIFY:

1. **Part List:** The package includes an antenna, coupler, cables, mounting hardware, antenna positioning template and connectors for the two way-radio. Use only the components supplied with the antenna (Refer to Figure 1).

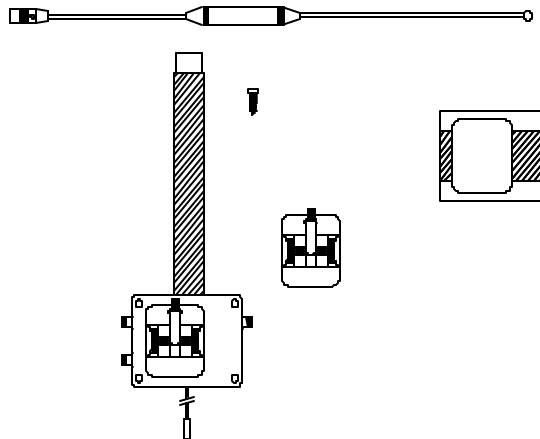

Figure 1 –Parts

2. **Bandwidth:** The VHF bandwidth for the antenna is 24 MHz wide and designed to operate in the VHF band from 150 MHz to 174 MHz. The UHF Band 106 MHz wide and designed to operate between 406 – 512 MHz. The cellular band is 90 MHz wide and designed to operate between 806 MHz to 896 MHz. Be certain that the antenna was tuned to the frequency required.

DO NOT ATTEMPT TO TUNE THIS ANTENNA!

Tip: Aftermarket tint must be removed before installation. OEM tint will not affect the performance of this antenna.

INSTALLATION:

1. **Preparation:** If installing the antenna in below 60° F. The glass, tape and coupler should be kept warm 30 minutes prior to installation. A curing time of one hour above 60° F is recommended to achieve maximum bond between adhesive tapes and glass.



NOTE: Clean glass with the alcohol pad and adhere coupling box. Clean the outside of the window with the same alcohol pad, remove the adhesive backing on foot and place over the left side of the coupling can (Refer to Figure 2- (Template & Foot). If installing the antenna in below 60° F. The glass, tape and coupler should be kept warm 30 minutes prior to installation. A curing time of one hour above 60° F is recommended to achieve maximum bond between adhesive tapes and glass. StI-co recommends using a hair dryer or heat gun to warm tape prior to placement of outside foot print.

- Foot Placement:** Place the template on the outside of window in such a manner, that if there are either defogger or AM/FM wires located in the glass, they do not fall in the cross hatched area. Be sure to place the template as high on the windshield as high as possible to insure that the grounding strap is long enough to be attached in the manner prescribed in figure 4. Attach the template to the window with scotch tape. Remove the protective backing on the antenna foot and place the foot thru the hole on the template as shown in figure 2.

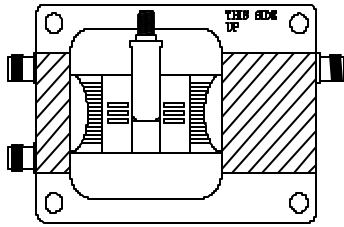

Figure 2- Template & Foot

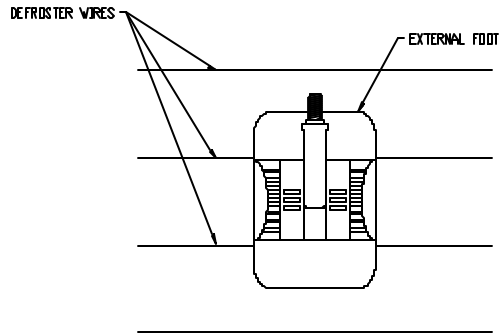

Figure 3 – Coupler/Exterior

- Coupler placement:** Remove the protective backing on the tape. Place the coupler on the inside of the window, over the template outline. Press firmly to secure the coupler. When the coupler is firmly secured, you can remove the template on the out side of the windshield.

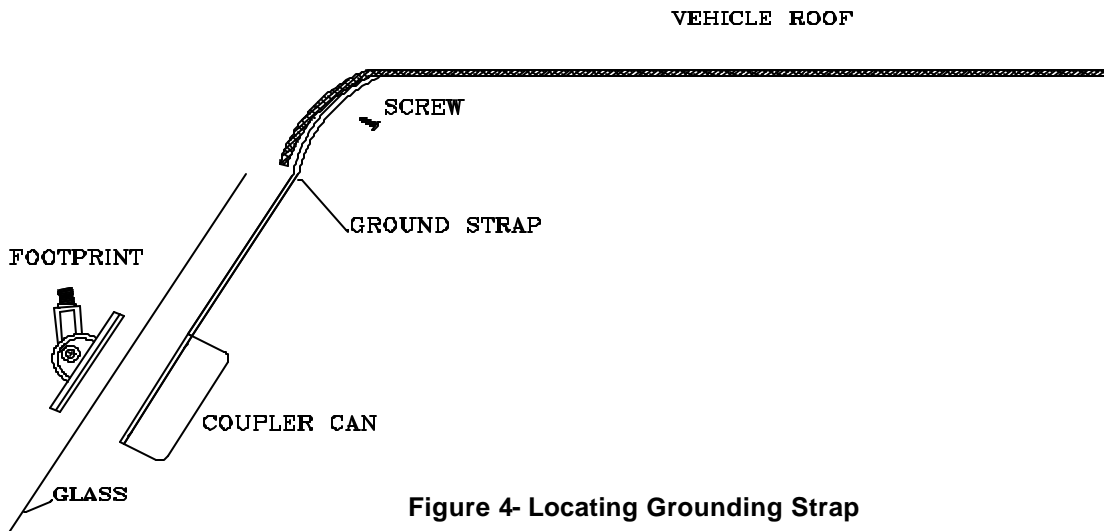

Figure 4- Locating Grounding Strap

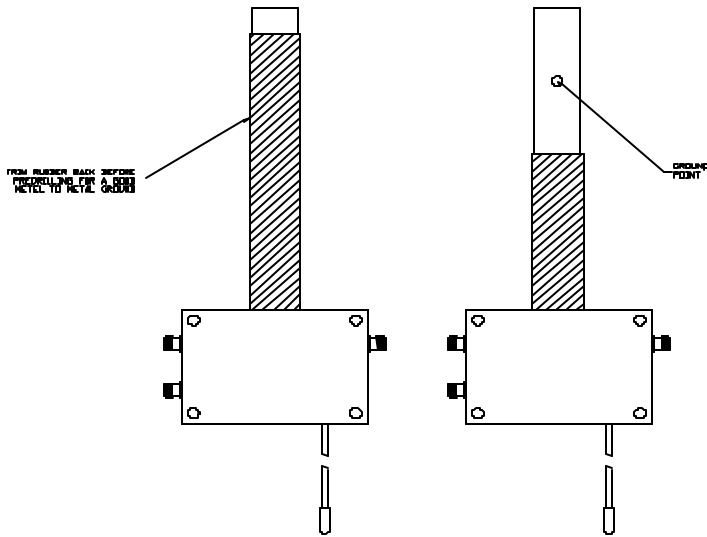

Figure 5 – Grounding preparation

Determine the location where you can pre-drill the grounding strap before screwing into the vehicle roof. Trim back the rubber insulation to expose the predrilled hole Refer to Figure 4-locating Ground Strap. Attach grounding strap using 3/8 x #6 sheet metal screw provided

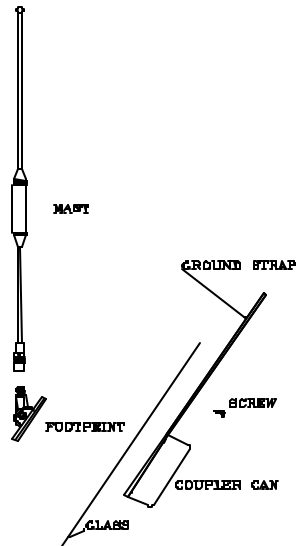

Figure 6 – General Assembly

3. **Assembly:** Thread the mast onto the foot and tighten the screws so that the mast stands vertically.



4. **Run Cables:** Route coaxial cables toward the two-way radio by tucking the cable under the rubber lip of the window trim.

Note: Be careful not to tear the sheath of cable when pulling through sharp body panels. If a hole appears in the cable's sheath, cover with several layers of a high quality electrical tape.

5. **Electromagnetic interference:** Do not coil feedline cable. Fold the cable upon itself rather than coiling. Do not tape or secure any feedlines to data or vehicle cables during installation.
6. **Cable Cutting:** If desired, cut the feedline cable to the length required to reach the transmitter.
7. **Install Connectors:** Refer to Figure 7 - Cable Stripping Dimensions (Drawing is not to scale).

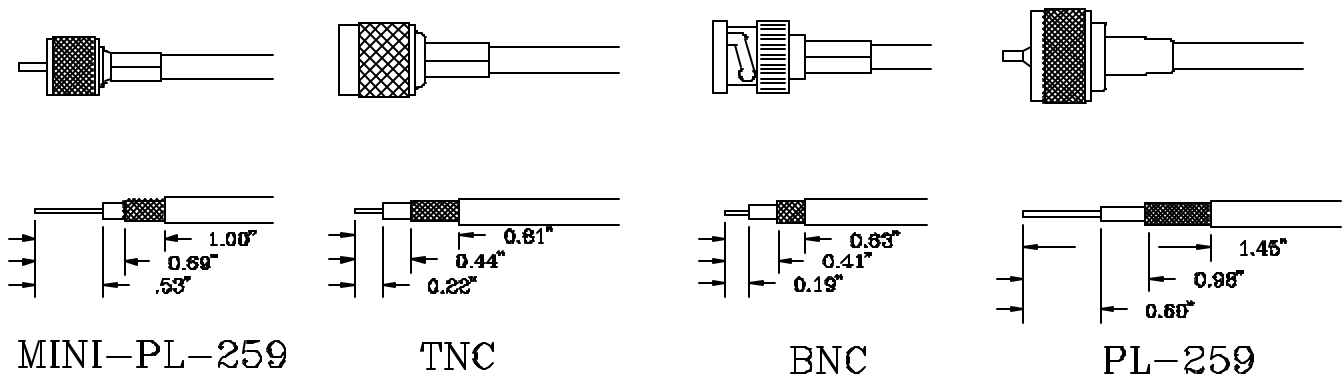

Figure 7 - Cable Stripping Dimensions

TESTING:

Installation testing must take place at the transmitter side of the feedline. Make sure all doors, hood, and trunk are closed.

Note: Some vehicles are sensitive to VHF frequencies. STI-CO suggests that you isolate feedlines and check for unwanted interference with the ignition switch on.

1. **Reflective Power:** A measurement of reflective power using a wattmeter, you can expect up to 11% reflected power. When results are greater than 11%, reposition antenna.
2. **SWR:** A measurement of SWR (standing wave ratio) will yield better than 2:1. If greater than 2:1, reposition antenna.
3. **Continuity:** A test of continuity between the center pin and ground, for this antenna will show as an open.

CAUTION: The mast must be removed at threaded section before entering a car wash.