

Cellular Mount Installation Considerations Trunk Lip, Dual Band, VHF/UHF Antenna

TKLP-DB-VHF/UHF

VERIFY:

1. **Part List:** The package includes antenna, cable(s), coupler, connectors, and hardware (See drawing). Use only the components supplied with the antenna. I.e. mast, couplers, and cables.
2. **Bandwidth:** VHF/UHF Broadband antennas are 24 MHz wide, within the range of 150-174 MHz, and 20 MHz wide between 406 and 512 MHz. Extended tuning ranges are available. Be certain that the antenna was tuned to the frequencies required.

INSTALLATION:

1. **Placement:** Select a desired location for the antenna; it may be mounted in the center of the trunk nearest to the rear window. If the antenna comes into contact with the window when raising the trunk lid, you may move it to either side of the trunk lid, away from the am/fm radio antenna.
- Note: Keep in mind that some vehicles will have aluminum or composite trunk lids.*
2. **How to attach:** Route coaxial cable with TNC connector through raised trunk lid. Tilt mounting base and hook the clamp bracket on trunk lip, avoid pinching of the cable.
 3. **Interconnect:** Refer to the VHF/Cellular Dual Band Cellular Antenna Configuration. Do not tape or secure any feedlines to data or vehicle cables during installation. Remove red fit caps and connect the VHF radio to the port marked "150" and the UHF radio to the "UHF" port.

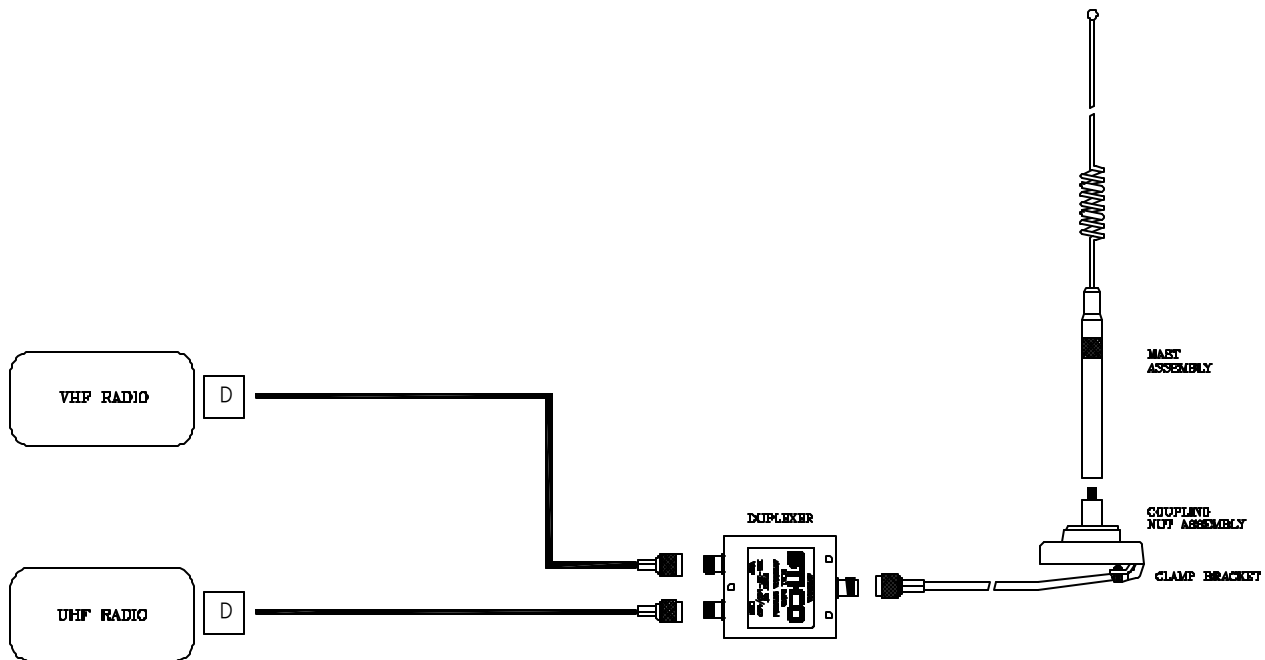

VHF/Cellular Dual Band Cellular Antenna Configuration

4. **Cable Cutting:** Cut the feedline cable to the appropriate length required to reach the transmitter. The feedline cable may be cut at any point between the coupler and the transmitter.
5. **Install Connectors:** Refer to Cable Stripping Dimensions (drawing is not to scale).

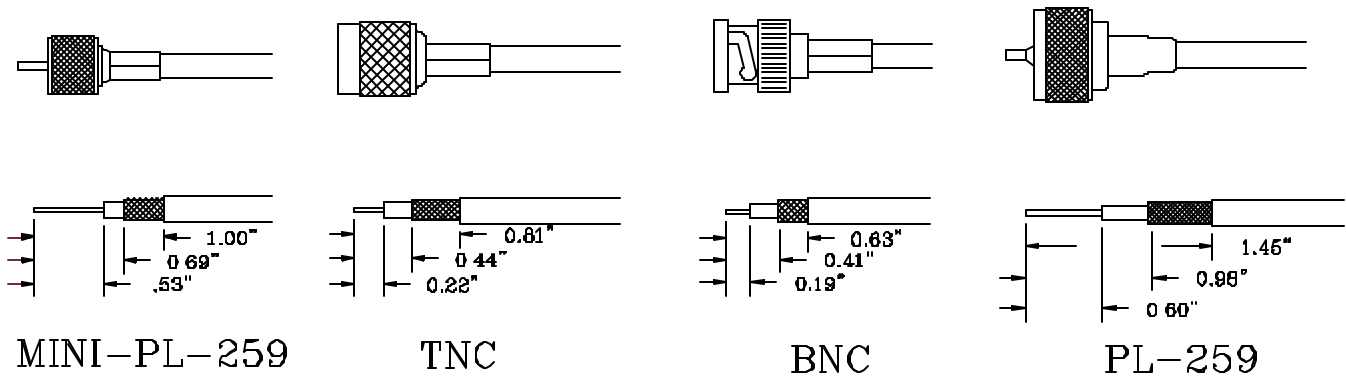

Cable Stripping Dimensions

TESTING:

Installation testing, if required, must take place at the transmitter side of the feedline. This will ensure that the cable connectors and cables have the proper continuity. Make sure all doors, hood, and trunk are closed. The duplexer can be part of the tuning network and needs to be in line for proper test results.

Note: Some vehicles are sensitive to VHF frequencies. STI-CO suggests that you isolate feedlines and check for unwanted interference with the ignition switch on. If problems persist, call STI-CO and ask for Technical Support.

1. **Reflective Power** - A measurement of reflective power using a wattmeter, you can expect up to 11% reflected power. When results are greater than 11%, recheck grounding.
2. **SWR** - A measurement of SWR (standing wave ratio) will yield better than 2:1. If greater than 2:1, recheck grounding.

CAUTION: The mast must be removed at the knurled portion of the mast assembly before entering a car wash.