



## Cellular Mount Installation Considerations Glass Mount, Superband<sup>®</sup>, 700 MHz Antennas

GLMT-SB-700

### VERIFY:

1. **Part List:** The package includes an antenna, coupler, cable, mounting hardware and connector for the two way-radio. Use only the components supplied with the antenna (Refer to Figure 1).

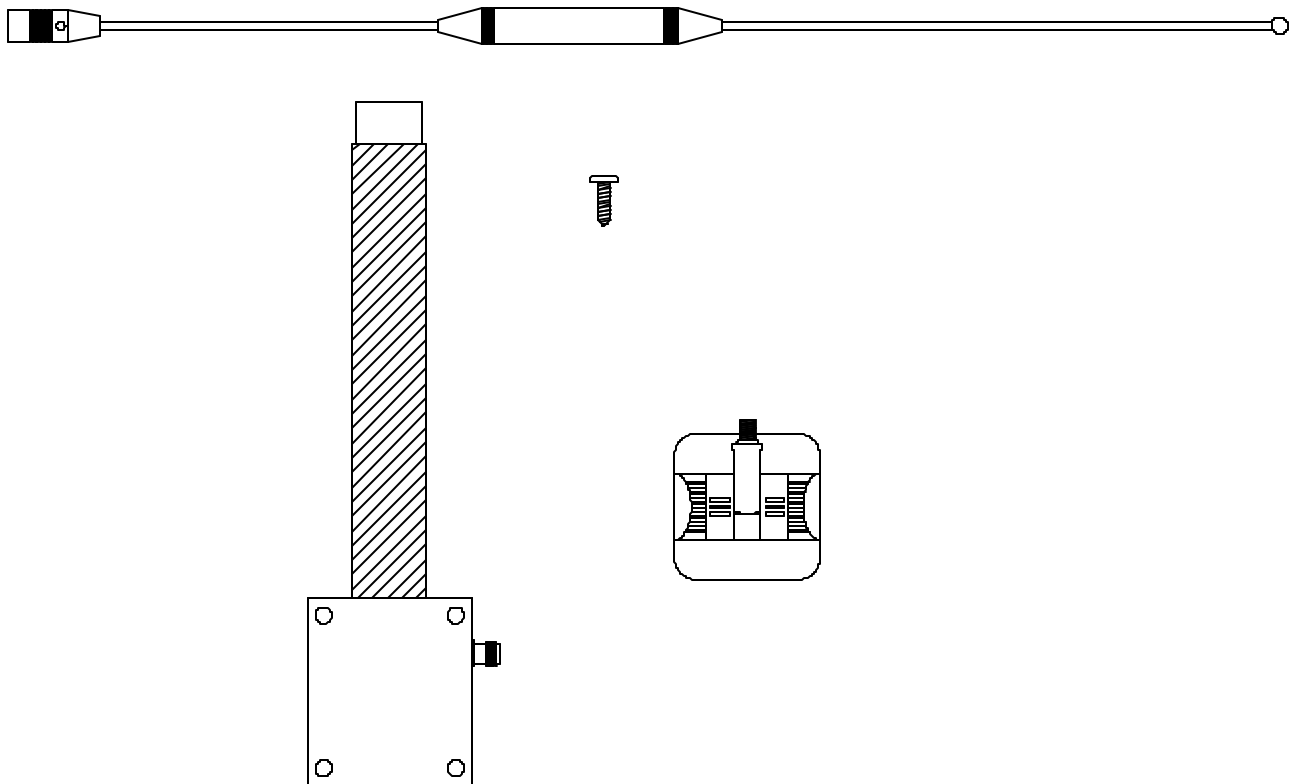

Figure 1 – General Assembly

**Bandwidth:** 700 MHz Superband<sup>®</sup> antennas are 60 MHz wide and are designed to operate between 760 MHz to 820 MHz unless otherwise specified. Be certain that the antenna was tuned to the frequency required.

### DO NOT ATTEMPT TO TUNE THIS ANTENNA!

*Tip: Aftermarket tint must be removed before installation. OEM tint will not affect the performance of this antenna.*



## INSTALLATION:

**Preparation:** The antenna base and automotive glass must be heated to between 60° and 110° F at the time of installation. A curing time of one hour above 60° F is recommended to achieve maximum bond between adhesive tapes and glass.

**Placement:** Select desired location on inside of window for coupling box so that the grounding strap makes contact with metal from the roof (Refer to Figure 2 – Locating Grounding Strap).

**Note:** DO NOT allow the middle of the coupling box/external foot to be located DIRECTLY OVER a defogger elements or AM/FM wire that may be located within the glass. Locate exterior foot between defogger wires.

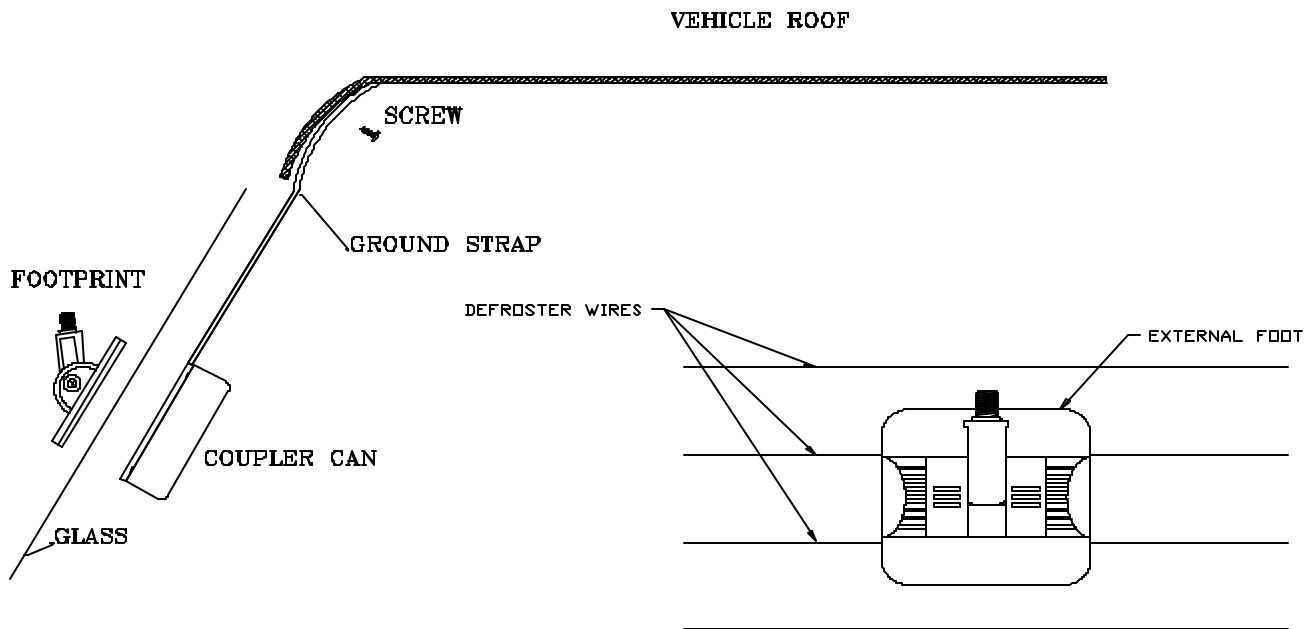

**Figure 2 – Locating Grounding Strap**

Determine the location where you can pre-drill grounding straps before screwing them in.

### Installation

1. Trim back the rubber insulation to expose the pre-drilled holes (Refer to Figure 4 – Grounding Strap Preparation).
2. Attach grounding straps using 3/8 X #6 sheet metal screw provided
3. Clean glass with the alcohol pad and adhere coupling box. Clean the outside of the window with the same alcohol pad, remove the adhesive backing on foot and place over the center of the coupling can (Refer to Figure 5 – General Assembly).

*Note: If installing the antenna in below 60° F. The glass, tape and coupler should be kept warm 30 minuetts prior to installation.*

**STI-CO also recommends using a hair dryer or heat gun to warm tape prior to placement of outside footprint.**

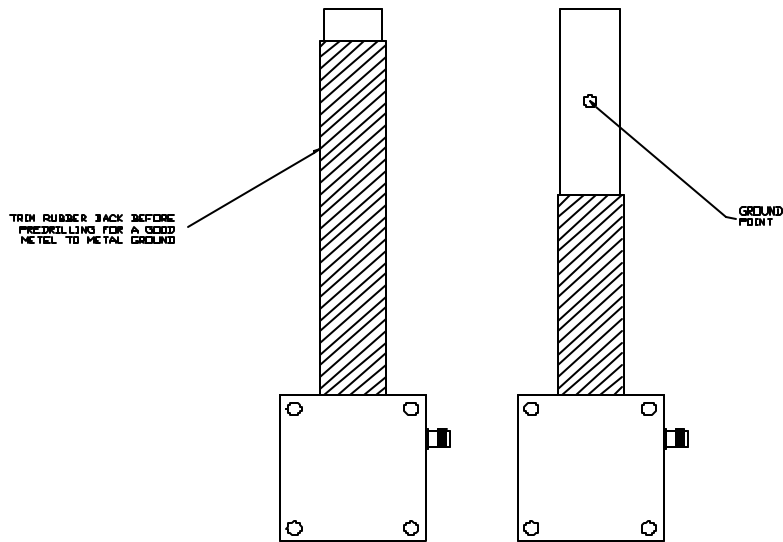

**Figure 4- Grounding Strap Preparation**

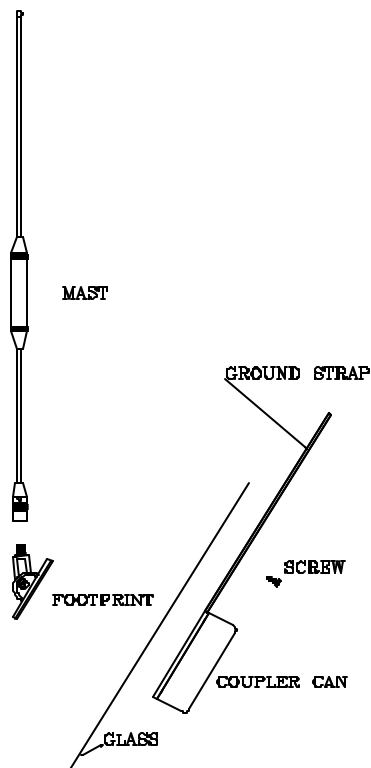

**Figure 5 - General Assembly**

*A curing time of one hour above 60° F is recommended to achieve maximum bond between adhesive tapes and glass.*

4. **Assembly:** Thread the mast onto the foot and tighten the screws so that the mast stands vertically.
5. **Run Cable:** Route coaxial cable toward the two-way radio by tucking the cable under the rubber lip of the window trim.



**Note:** Be careful not to tear the sheath of cable when pulling through sharp body panels. If a hole appears in the cable's sheath, cover with several layers of a high quality electrical tape.

6. **Electromagnetic interference:** Do not coil feedline cable. Fold the cable upon itself rather than coiling. Do not tape or secure any feedlines to data or vehicle cables during installation.
7. **Cable Cutting:** If desired, cut the feedline cable to the length required to reach the transmitter.

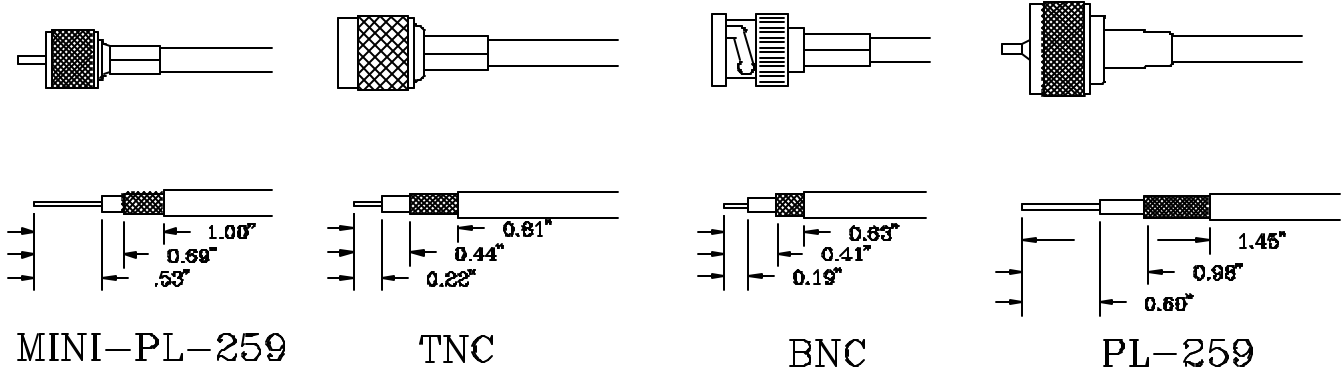

**Figure 6 - Cable Stripping Dimensions**

8. **Install Connectors:** Refer to Figure 6 for cable stripping dimensions (Drawing is not to scale).

## TESTING:

Installation testing must take place at the transmitter side of the feedline. Make sure all doors, hood, and trunk are closed.

**Note:** STI-CO suggests that you isolate feedlines and check for unwanted interference with the ignition switch on.

1. **Reflective Power:** A measurement of reflective power using a wattmeter, you can expect up to 11% reflected power. When results are greater than 11%, reposition antenna.
2. **SWR:** A measurement of SWR (standing wave ratio) will yield better than 2:1. If greater than 2:1, reposition antenna.
3. **Continuity:** A test of continuity between the center pin and ground, for this antenna will show as an open.

**CAUTION:** The mast must be removed at threaded section before entering a car wash.