



## Cellular Mount Installation Considerations Glass Mount, Superband ®, VHF Antennas for SUV's

### GLMT-SB-VHF-SUV

#### VERIFY:

1. **Part List:** The package includes an antenna, coupler, cable, mounting hardware and connector for the two way-radio. Use only the components supplied with the antenna (Refer to Figure 1).

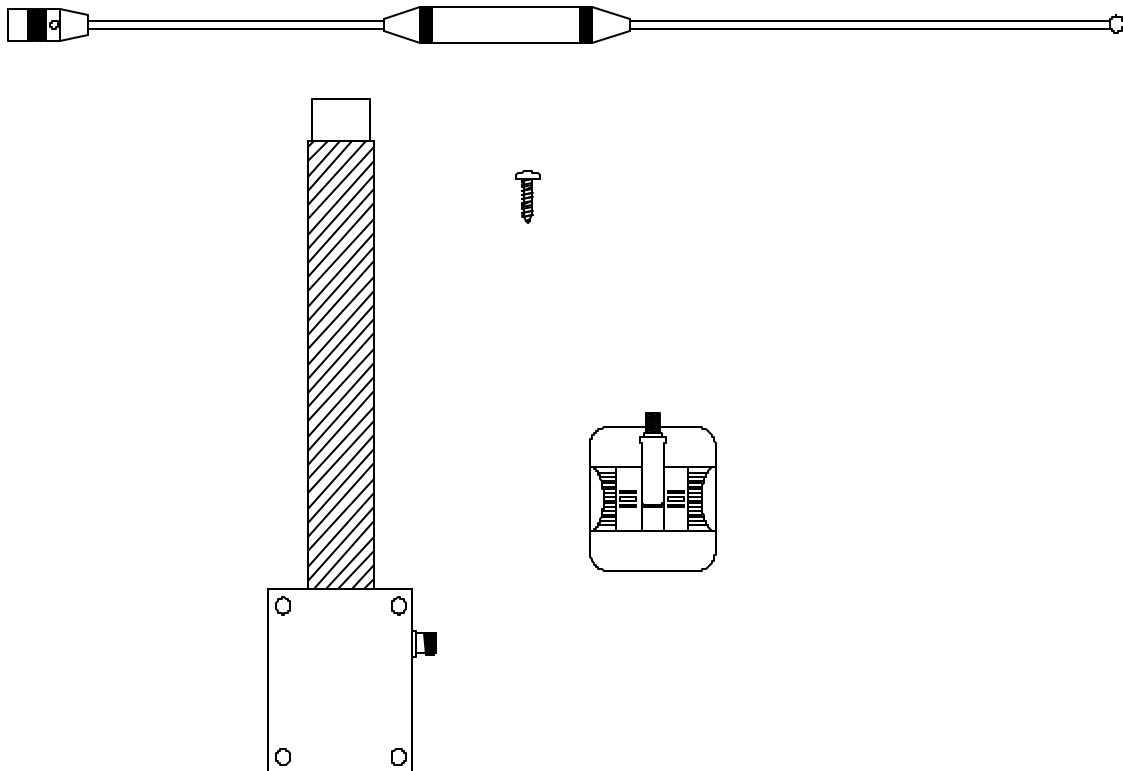

Figure 1 – General Assembly

**Bandwidth:** VHF Superband ® antennas are 24 MHz wide and are designed to operate between 150 MHz to 174 MHz unless otherwise specified.

#### **DO NOT ATTEMPT TO TUNE THIS ANTENNA!**

*Tip: Aftermarket tint must be removed before installation. OEM tint will not affect the performance of this antenna.*



## INSTALLATION:

**Preparation:** The antenna base and automotive glass must be heated to between 60° and 110° F at the time of installation. A curing time of one hour above 60° F is recommended to achieve maximum bond between adhesive tapes and glass.

**Placement:** Select desired location on inside of window for coupling box so that the grounding strap makes contact with metal from the roof (Refer to Figure 2 – Locating Grounding Strap).

Determine the location where you can pre-drill grounding straps before screwing them in.

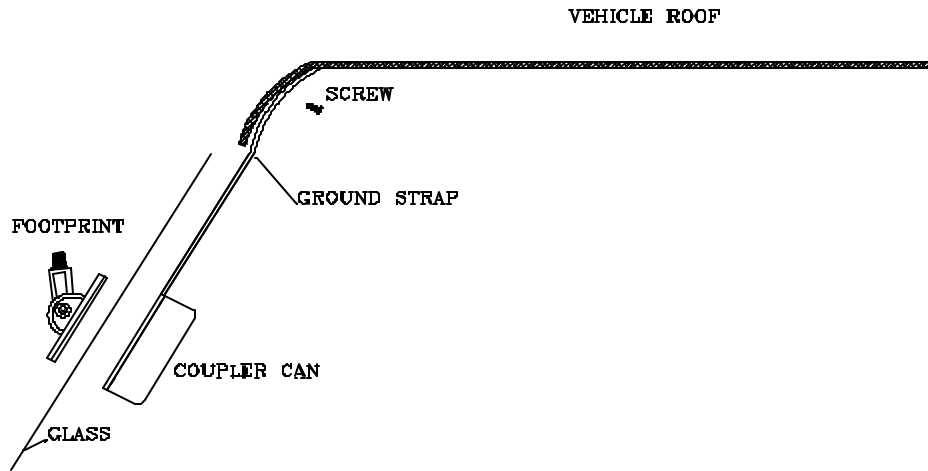

Figure 2 – Locating Grounding Strap

### Installation

1. Trim back the rubber insulation to expose the pre-drilled holes (Refer to Figure 3 – Grounding Strap Preparation).
2. Attach grounding straps using 3/8 X #6 sheet metal screw provided.

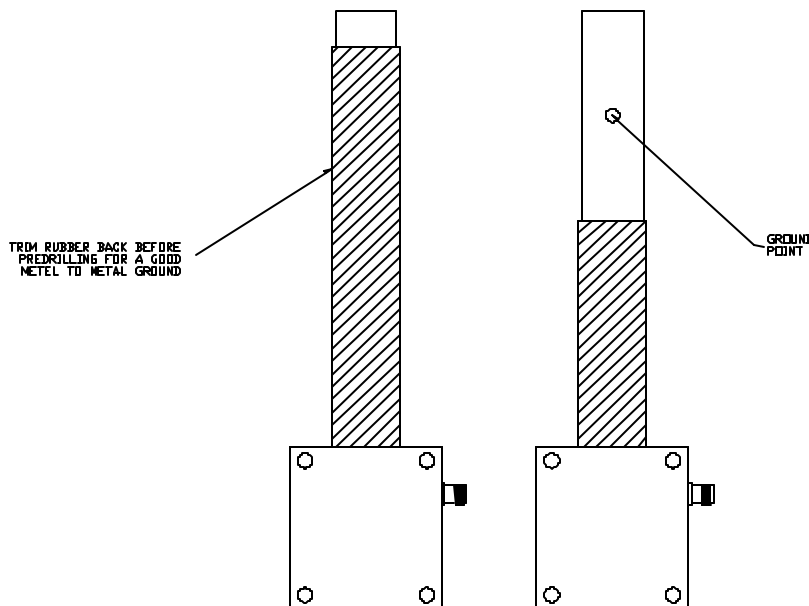

Figure 3 – Grounding Strap Preparation



3. Clean glass with the alcohol pad and adhere coupling box.
4. Clean the outside of the window with the same alcohol pad, remove the adhesive backing on foot and place over the center of the coupler can (Refer to Figure 4 – General Assembly).

*Note: If installing the antenna in below 60° F. The glass, tape and coupler should be kept warm 30 minuets prior to installation.*

**STI-CO also recommends using a hair dryer or heat gun to warm tape prior to placement of outside footprint.**

*A curing time of one hour above 60° F is recommended to achieve maximum bond between adhesive tapes and glass..*

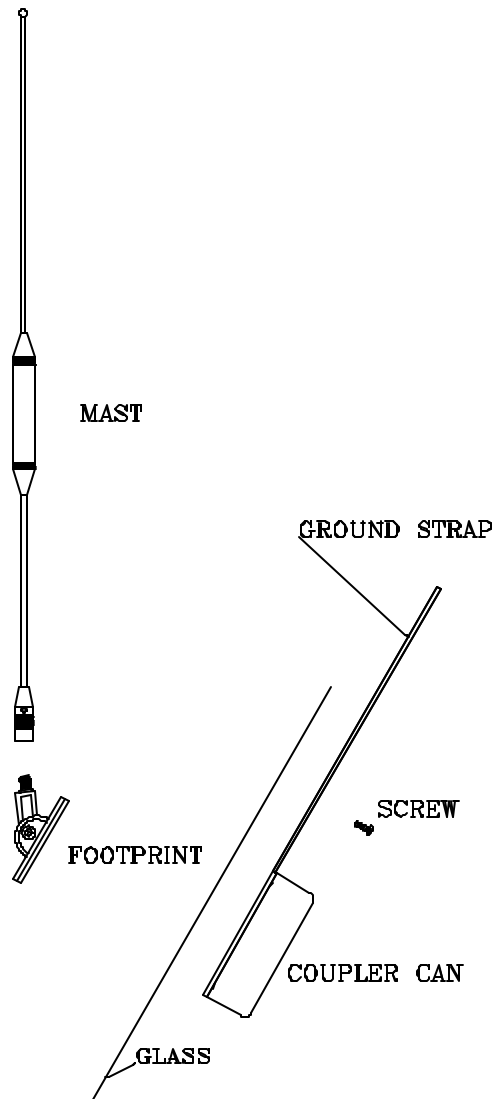

**Figure 4 – General Assembly**

5. **Assembly:** Thread the mast onto the foot and tighten the screws so that the mast stands vertically.



6. **Run Cable:** Route coaxial cable toward the two-way radio by tucking the cable under the rubber lip of the window trim.

**Note:** Be careful not to tear the sheath of cable when pulling through sharp body panels. If a hole appears in the cable's sheath, cover with several layers of a high quality electrical tape.

7. **Electromagnetic interference:** Do not coil feedline cable. Fold the cable upon itself rather than coiling. Do not tape or secure any feedlines to data or vehicle cables during installation.
8. **Cable Cutting:** If desired, cut the feedline cable to the length required to reach the transmitter.
9. **Install Connectors:** Refer to Figure 5 for cable stripping dimensions (Drawing is not to scale).

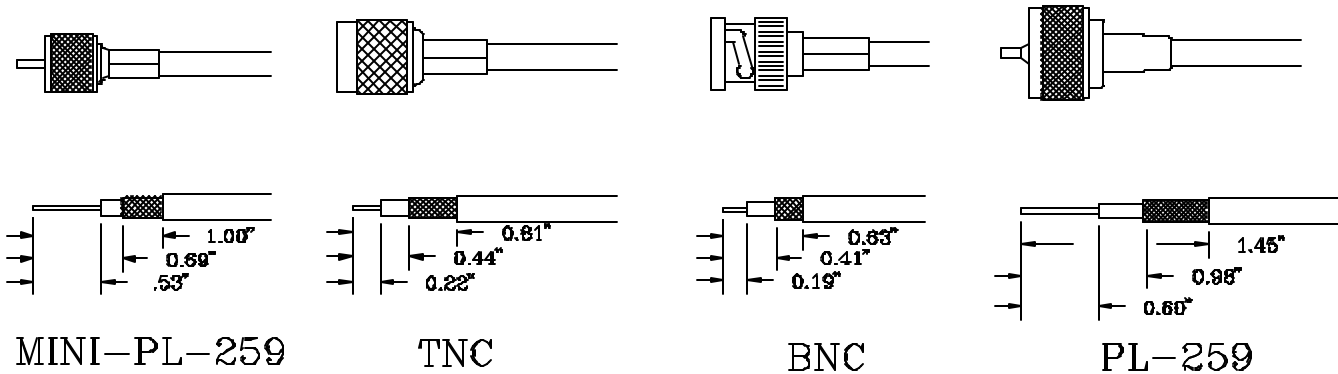

Figure 5 - Cable Stripping Dimensions

## TESTING:

Installation testing must take place at the transmitter side of the feedline. Make sure all doors, hood, and trunk are closed.

**Note:** Some vehicles are sensitive to VHF frequencies. STI-CO suggests that you isolate feedlines and check for unwanted interference with the ignition switch on.

1. **Reflective Power:** A measurement of reflective power using a wattmeter, you can expect up to 11% reflected power. When results are greater than 11%, reposition antenna.
2. **SWR:** A measurement of SWR (standing wave ratio) will yield better than 2:1. If greater than 2:1, reposition antenna.
3. **Continuity:** A test of continuity between the center pin and ground, for this antenna will show as an open.

**CAUTION:** The mast must be removed at threaded section before entering a car wash.